

Resistance-transmitter RT 500

Resistance range from 50Ω to 100kΩ

Features

- 12 Bit AD/DA processor technology with 250Hz realtime execution
- Teach-in-programming for initial and final value
- 2-/3-wire connection
- Output for 0/4 ... 20mA, simultaneous 0/2 ... 10V
- Increase or decrease output characteristic programmable
- Operation mode indicated by 2-color-LED
- Supply voltage 85 ... 265V AC or 10 ... 30V AC/DC
- 22.5mm case for DIN rail mounting



General information

RT500 transmitter convert resistance- or potentiometer signal into industry standard signals. Initial and final value may be in the range of 0...100kOhm. Easy programming by Teach-in. The measurement range will be selected automatically. The input circuit is designed in 3-wire technology and can provide compensation of line resistance. The linear output-signal is generated between minimum and maximum input resistance.

Short information

Programming	input programming and output configuration is selected with DIP switches at the front panel
Watch-dog	watches program running and provides auto-reset in case of error
Data memory	protection against power failure
Current output	maximum burden 1kΩ

Technical data

Power supply

Supply voltage	: 85 ... 265V AC or 10 ... 30V AC/DC
Frequency AC	: 47 ... 63 Hz
Power consumption	: < 3VA
Operating temperature	: -10 ... +50°C
Rated voltage	: 500V \approx according to German VDE 0110 Group 3 between input, output / power supply
Test voltage	: 4 kV- between power supply and input / output
CE-conformity	: EN55022, IEC1000-4-4/5/11/13, EN60555

Input

Resistance range	: R_{max} : 50 Ω ... 100k Ω , cond.: $\Delta R \geq 0.5 R_{max}$ (lower values on request) increasing or decreasing output characteristic programmable.
------------------	---

Measuring voltage and - current

measuring voltage	measuring current			
	6,25mA	2,5mA	250 μ A	25 μ A
1V	100 Ω	250 Ω	2,5k Ω	25k Ω
2V	--	500 Ω	5k Ω	50k Ω
4V	--	1k Ω	10k Ω	100k Ω

Resistance values for maximum resolution

Resolution	: 600 ... 3000 digit (depends on measurement range)
Sampling frequency	: 250 Hz real-time processing
Cable resistance	: 10 Ω max. automatic compensation in 3-wire-circuits with symmetric line-resistance

Output

Current output	: 0/4 ... 20mA switch selectable; load \leq 1k Ω	No isolation between input and output
Voltage output	: 0/2 ... 10V switch selectable; load 15mA max., short-circuit-protection (simultaneous to current output 5mA max.)	
Rise time (t_{95})	: < 8ms	
Accuracy	: < 0.2%	
Temperature coefficient	: \leq 100ppm/ $^{\circ}$ C	

Case	: standard case of polycarbonate 8020 UL94V-1
Weight	: approx. 200g
Connection	: screw-terminals with pressure plate max 2.5 mm ² , wire
Protection	: Case IP30, terminals IP20 finger safe acc. to German BGV A2

Programming

Programming the resistance measuring range	
1	Set resistance (Rmin) at terminals 1,2,3
2	S1 ON \rightarrow RT500 stores value Rmin
3	-- LED flashes green = o.k. -- LED flashes red = error (please refer to status display)
4	S1 OFF
5	Set resistance (Rmax) at terminals 1,2,3
6	S2 ON \rightarrow RT500 stores value Rmax
7	please refer to no. 3
8	S2 OFF \rightarrow Programming of resistance measuring range is now completed
9	Adjust S3 to set desired output configuration

Status display LED

S1(S2)	LED	Status
Off	green	Operation
	red	Measuring range exceeded or cable interruption
	red/green flashing	Last programming was invalid. Resistance value could not be stored.
On	LED off (2 Sec.)	Resistance value at terminals 1,2,3 is stored
	green flashing	Resistance value measured has been stored in EEPROM
	red flashing	Resistance difference is smaller than 20 ... 50% (depending on measuring range) of Rmax
	red	Resistance value exceeds 100k Ω . Resistance value could not be stored.

Connection diagram

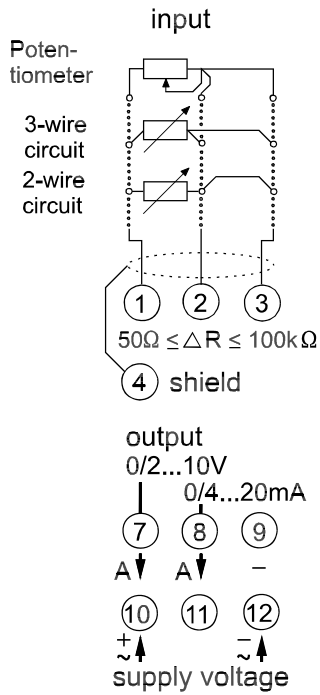

Caution!
Do not connect input with output and shield with PE

Front panel controls

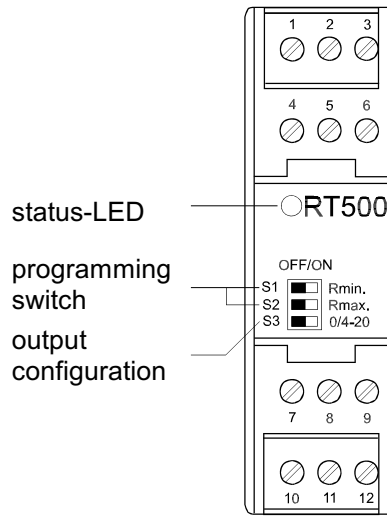

Dimensions

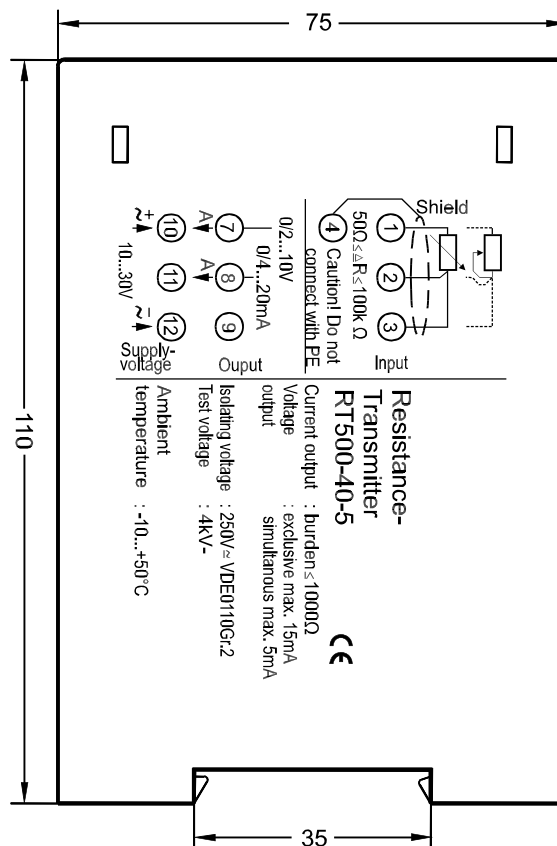
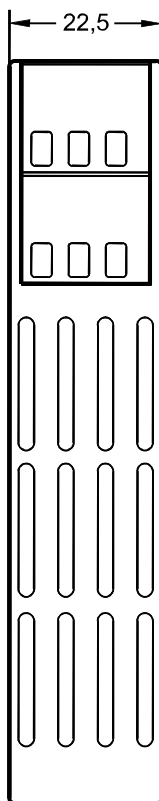

Caution!
Mounting of multiple units without distance is only permitted vertical orientation!

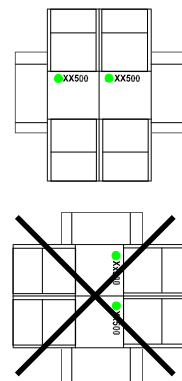

TS35 DIN rail mounting acc. to DIN 46277 and DIN EN 50022

Order code

RT5000 - ^{1.} - ^{2.}

1. Measuring range

40 Rmax programmable in range 50Ω ... 100kΩ

2. Supply voltage

0 85 ... 265V AC

5 10 ... 30V AC/DC

Note: Configuration is possible ex factory without extra charge.
Please state the desired data when ordering.
E.g.: input 0 ... 250Ω or 150 ... 800Ω.