

# Digital Panelmeter DP 4824B

voltage - current - resistance - shunt voltage - measuring transformer

all in one

all in one

## Features

- Multipurpose input  
0/4 ... 20mA, 0 ... 2.5V, 0/2 ... 10V DC  
and potentiometer
- Multipurpose for shunt voltage  
and measuring transformers : 0 ... 60mV DC,  
0 ... 150mV DC and 0 ... 1mA DC
- Adjustable display range  
-19999 ... +19999  
(no extern signal source necessary !)
- Decimal point switch selectable
- Display LED red or green 8mm
- Two 20-turn adjustable trimmers for initial value and span  
(coarse and fine tuning)
- Supply voltage 10.8 ... 30V DC  
whit isolation.
- Front protection IP54 (IP65 optional)
- Plug-in screw terminals



## General information

Digital panelmeter DP4824B are designed for measurement applications in process technology and automation. The small cases are suitable for installation in control units and panel boards. The universal conception of the input's allows indication of all physical dimensions, which can be converted to 0/4 ... 20mA, 0/2...10V DC. The input-configuration can be programmed from the side, without opening the case. The display range can be adjusted without external signal source. Input and supply voltage are isolated. The other model of the DP4824B is useful to operate with shunt voltage and signal from measuring transformer.

## Technical data

### Power supply

Supply voltage	: 10.8...30V DC
Power consumption	: approx. 1.2VA
Working temperature	: -10...+60°C
Test voltage	: 500V DC input / supply voltage
CE - conformity	: EN 55022, IEC1000-4-2/4/11

### Input (multipurpose device)

Voltage input	: $R_i = 40k\Omega$ (max. 48V)
Current input	: $R_i = 125\Omega$ (max. 60mA)

### Input (shunt purpose device)

Voltage input	: $R_i = 25k\Omega$ (max. 48V)
Current input	: $R_i = 60\Omega$ (max. 20mA)

### Accuracy (standard device)

Indication error	: < 0.025% +/- 1 digit
Temperature coefficient	: < 25ppm/°K

### Display

Conversion rate	: 4½-digit 8mm LED red or green
Range	: approx. 2/s
Decimal point	: 3999 digit
Overflow indicator	: switch selectable
	: flashing <b>000</b> at pos./neg. Sign

### Case

Weight	: slide-in unit according to DIN 43700 of Noryl GFN 2 SE 1
Connection	: 0.1kg
Protection	: plug-in screw terminals, max 1.5mm <sup>2</sup> , : Front IP54 (IP65 as option), terminals IP20, : finger safe acc. to German VBG4.

## Dimensions

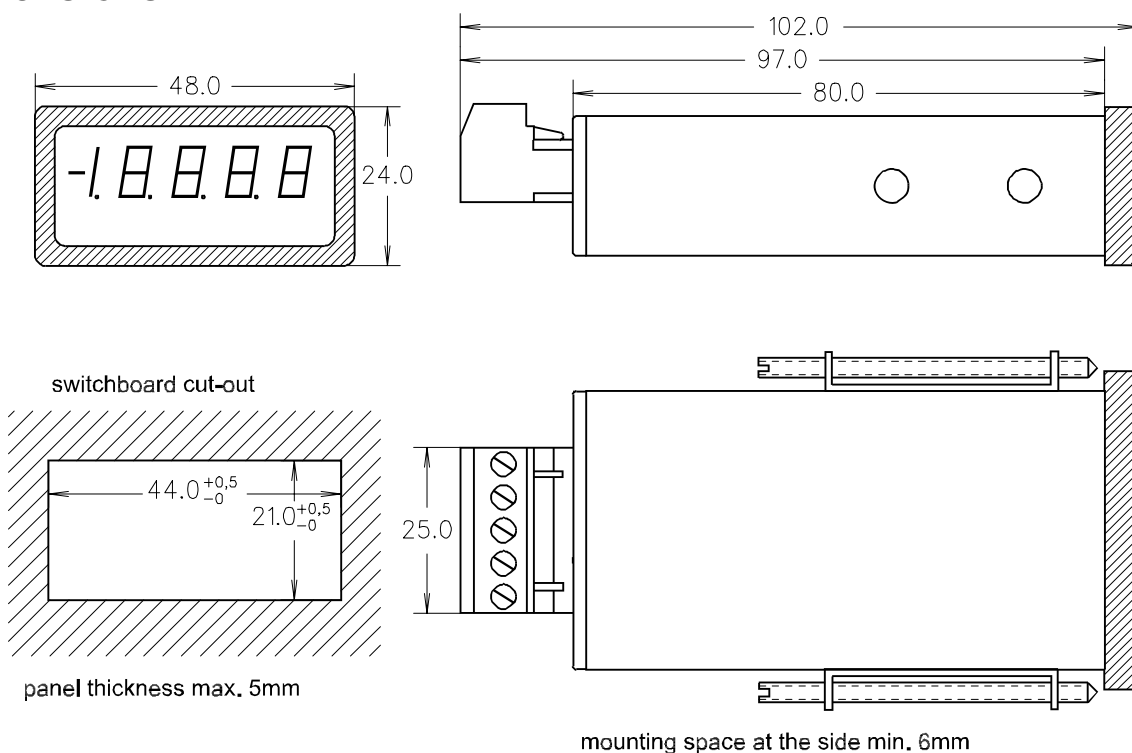

## Connection diagram

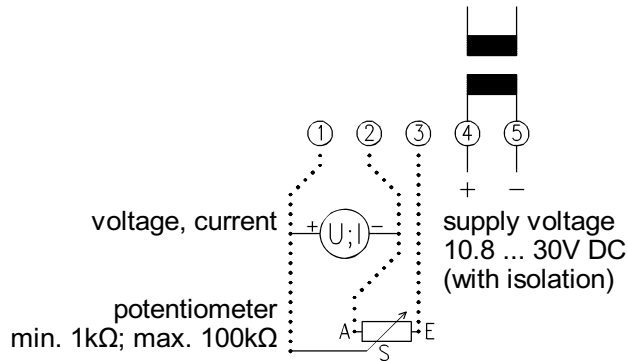

## Dimension

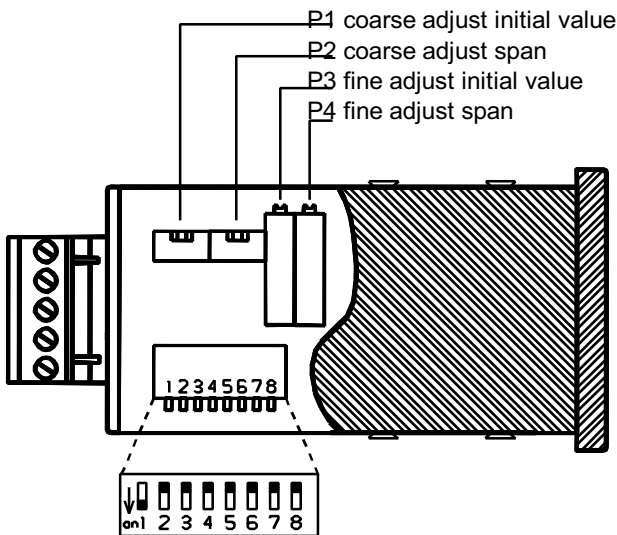

- DIP-switch function S4...S8  
 S1...S3 look at chart input configuration
- S4 ON 4. decimal point (1.8888)
  - S5 ON 3. decimal point (18.888)
  - S6 ON 2. decimal point (188.88)
  - S7 ON 1. decimal point (1888.8)
  - S8 ON see chart Adjustment-range

### Input configuration (multipurpose device)

Input	S1	S2	S3
0 ... 2.5V DC	OFF	OFF	OFF
2 ... 10V DC	ON	OFF	ON
0 ... 10V DC	ON	OFF	OFF
4 ... 20mA	OFF	ON	ON
0 ... 20mA	OFF	ON	OFF
0 ... 1/100kΩ	OFF	OFF	OFF

### Input configuration (shunt purpose device)

Input	S1	S2	S3
0 ... 60mV DC	OFF	OFF	OFF
0 ... 150mV DC	ON	OFF	OFF
0 ... 1mA	OFF	ON	OFF

## Adjustment-range

Initial value	DIP-switch S8	Span
= 0	ON	max. ±19999 Digit
≠ 0*	OFF	

\* initial value adjustable in range ± 50% of the span

A special adjust-instruction for the multipurpose device is a part of delivery.

## Order code

<b>DP 4824B -</b>	1. <input style="width: 40px; height: 20px;" type="text"/>	2. <input style="width: 40px; height: 20px;" type="text"/>	3. <input style="width: 40px; height: 20px;" type="text"/>	4. <input style="width: 40px; height: 20px;" type="text"/>
-------------------	---	---	---	---

1.

<b>Display</b>
5: LED 8mm red
6: LED 8mm green

3.

<b>Front protection</b>
1: IP54
2: IP65

2.

Measuring range	Adjustment range
10: Multipurpose device DIP-switch for: 0 ... 10V DC, 2 ... 10V DC, 0 ... 2,5V DC, 0 ... 20mA, 4 ... 20mA or Poti min. 1kΩ, max. 100kΩ	Display : Initial value and span adjustable by customer*.
30: Shunt purpose device DIP-switch for: 0 ... 60mV DC, 0 ... 150mV DC or 0 ... 1 mA	
*Custom measuring range and factory adjustment without any charge on request.	

4.

<b>Unit</b> dimension on the face plate
e.g. °C
°F
μS/cm
min <sup>-1</sup>
bar
hPa
ppm
%
A
V
please state different labels in clear text.

# Adjustment instruction Digital Panelmeter DP 4824B

## (multi purpose device)

To adjust the DP4824B you don't need any measuring instruments or simulator. Only a 2mm screwdriver is necessary.

There are two kinds of measurement ranges to adjust

1. Display initial value = 0 ➤ please proceed item A).
2. Display initial value ≠ 0 ➤ please proceed item B).

### A). Display initial value = 0

- ① Please disconnect wires from terminals 1 ... 3 . DIP-switch S8 "ON".  
Apply supply voltage.

- ② Display zero adjust

Input configuration

S1	S2	S3
ON	OFF	OFF

Adjust display with P1 coarse and P3 fine to 0000.

- ③ Display final adjust (span)

Input configuration

S1	S2	S3
OFF	OFF	OFF

Link between terminals 1 und 3.  
Adjust display with P2 coarse and P4 fine to the final value

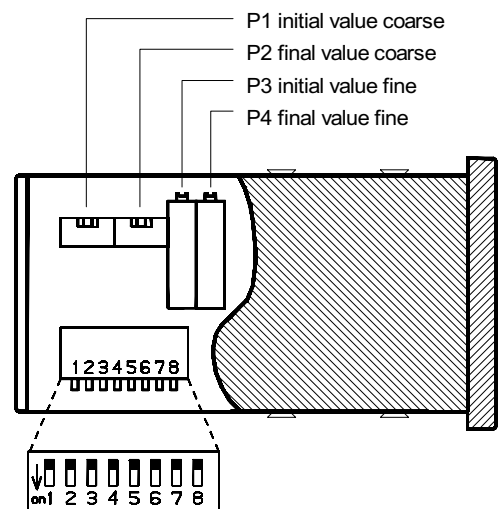

- ④ If its necessary go to step ② and ③ until the values are in the range.

- ⑤ Configurate input with DIP-switch S1 ... S3 wanted range (see table). Activate decimal point with DIP-switch S4 ... S7 (if needed). Connect wires to terminals 1 ... 3.

Input	S1	S2	S3
0...2.5V DC	OFF	OFF	OFF
2...10V DC	ON	OFF	ON
0...10V DC	ON	OFF	OFF
4...20mA	OFF	ON	ON
0...20mA	OFF	ON	OFF
0...1/100kΩ	OFF	OFF	OFF

Function of DIP-switch S4-S7
S4=ON ➤ display <b>1.0000</b>
S5=ON ➤ display <b>10.000</b>
S6=ON ➤ display <b>100.00</b>
S7=ON ➤ display <b>1000.0</b>

## B). Display initial value ≠ 0

---

- ① See page 1
  - ② See page 1  
DIP-switch S8 "OFF".
- 

- ③ Adjust display range

Input configuration

S1	S2	S3
ON	OFF	OFF

Link between terminals 1 and 3.  
Adjust display with P2 coarse to  $\frac{1}{4}$  of the span  
(see example).

Example: Display range -120,00 ... +180,00  $\Rightarrow$  span = 30000 digit  
adjust  $\frac{1}{4}$  span =  $30000/4 = 7500$  digit

---

- ④ Adjust initial value

Input configuration as step 3  
remove link from terminals 1 and 3.  
Adjust display with P1 coarse to initial value  
(see example step 3 -12000 digit).

---

- ⑤ Check display final value

Input configuration

S1	S2	S3
OFF	OFF	OFF

Link between 1 and 3  
Check final value(see example 18000 digit)  
if necessary fine adjust with P4.

---

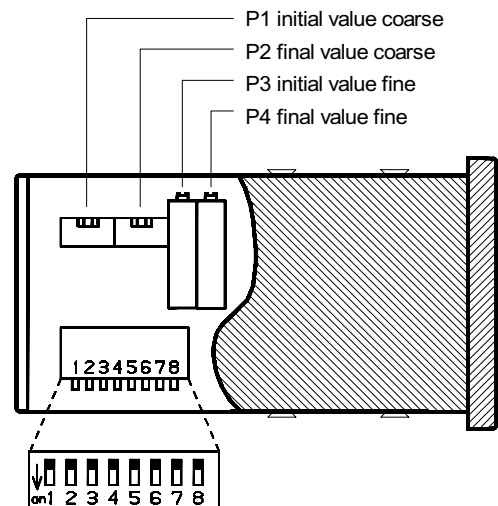

- ⑥ Check display initial value

Input configuration

S1	S2	S3
ON	OFF	OFF

Remove link from terminals 1 and 3.  
Fine adjust for initial value with P3.  
(see example -12000 digit).

---

- ⑦ Repeat step ⑤ and ⑥ until no more correction is necessary.
- 

- ⑧ Configure input with DIP-switch S1 ... S3 wanted range (see table). Activate decimal point with DIP-switch S4 ... S7 (if needed). Connect wires to terminals 1 ... 3.