

Strain-Bridge Converter DMS 1000

Weight - Force - Pressure - Torque with DMS Strain-Bridges

Features

- 1- or 2 way action, e.g. force or force / traction programmable
- Teach-in function
- Front side LCD-Display with backlighting
- Programming via front keypad
- Tare-function (internal / external)
- Integrated bridge-supply 2.5V / 5V / 10V
- Analog output 0/4...20mA; 0...10V DC
- 1 Alarm output, relay SPDT
- Wall- and DIN-rail TS35 mounting



General

The DMS1000 converts small signal output of any common strain bridges (load cells) into a standard signal 0/4...20mA, 0...10V DC. Bridge supply and an input for tare fade-out is included.

If an application needs more than one load cell, it is necessary to connect a strain bridge booster SBB1616 between load cells and DMS1000. It is possible to connect max. 6 load cells at the SBB1616.

Short information

| | |
|-------------------|--|
| Programming | The device will be programmed via front-side membrane keypad in connection with integrated LCD-Display. |
| Teach-in function | When operating with two reference weights, the DMS1000 can calculate the bridge-sensitivity of an installed load cell, respectively the arithmetic average value of the sensitivity if several load cells are installed. |
| Tare-function | The displayed value can be set to "0" by keypads or external control signal. |
| Alarm output | Switching performance for the alarm output is programmable as minimum or maximum function. The status of the output will be displayed. |
| Analog output | DMS1000 offers an analog output signal 0/4 ... 20mA or 0 ... 10V DC proportional to the mechanical load within the programmed measuring range. |
| Sense input | The sense input is specified to compensate line resistance between DMS strain-bridge (load cell) and DMS1000. |

Technical Data

Power supply

| | |
|---------------------|---|
| Supply voltage | : 230V AC $\pm 10\%$; 115V AC $\pm 10\%$; 24V AC $\pm 10\%$ or 24V DC $\pm 15\%$ |
| Power consumption | : max. 3.5VA |
| Working temperature | : -10 ... +55°C |
| Rated voltage | : 250V~ nach VDE 0110 between, input, analog output / relay output / supply voltage, Degree of pollution 2, over-voltage categoric III |
| Test voltage | : 4kV-, between input, analog output / relay output / supply voltage |
| CE - conformity | : EN55022, EN60555, IEC1000-4-3/4/5/11/13 |

Input

| | |
|-------------------------|--|
| Bridge supply | : 2.5V / 5V / 10V DC ; programmable; max. 50mA |
| Bridge sensitivity | : 0.4 / 0.2 / 0.1 ... 5.00mV / V |
| Sense connection | : Line resistance of max. 10 Ω can be compensated |
| Accuracy | : < 0.1% ± 2 Digit |
| Temperature coefficient | : 0.005%/K |

| | |
|---------------|--|
| Display | : LCD Dot-Matrix 2 lines 8 characters each, character height 5mm, backlighting |
| Display range | : $\pm 9999(0)$ digit with leading zero suppression |

Output

| | |
|---------------|---|
| Relay | : SPDT <250V AC<250VA<2A, <300V DC<50W<2A |
| Analog output | : 0/4 ... 20mA burden $\leq 500\Omega$ or 0 ... 10V load max 5mA, programmable (not isolated from measuring input) |

-Accuracy : 0.1%; TK 0.01% / K

| | |
|------|--|
| Case | : Standard case Polycarbonate 8020 UL 94V-1, DIN-rail TS35 mounting, or wall mounting |
|------|--|

| | |
|------------|--|
| Weight | : max. 390g |
| Connection | : Screw terminals, max. 4mm ² |
| Protection | : Case IP40, terminals IP20, finger safe acc. to German BGV A2 |

Dimensions:

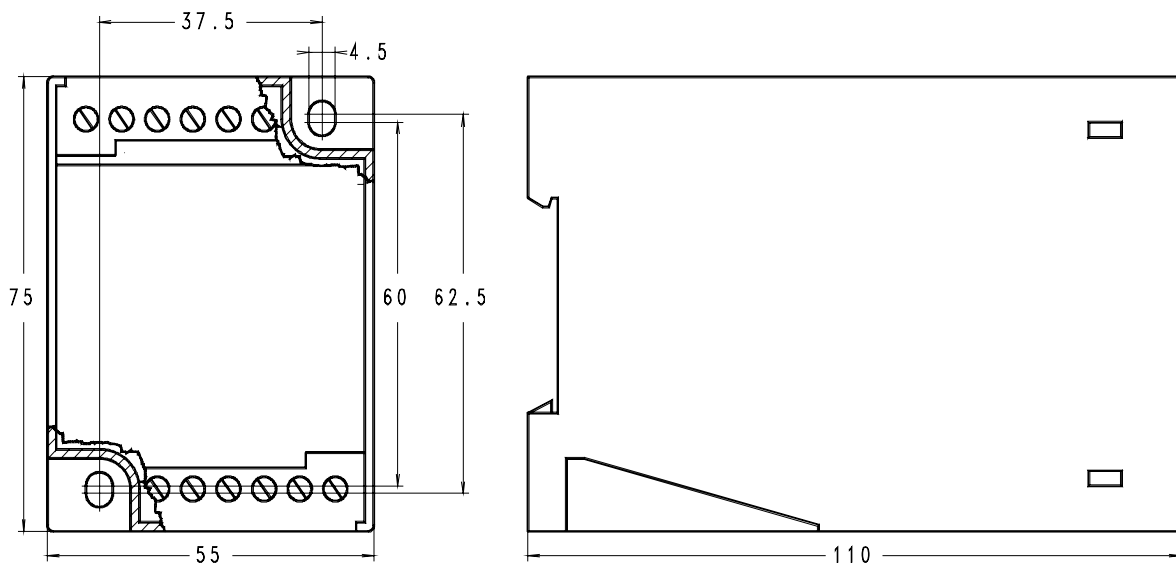

Wall-mounting with 2 screws M4 acc. to DIN46121 / DIN 43660
or DIN-rail TS35 acc DIN 46277 and DIN EN 50022

Connection diagram:

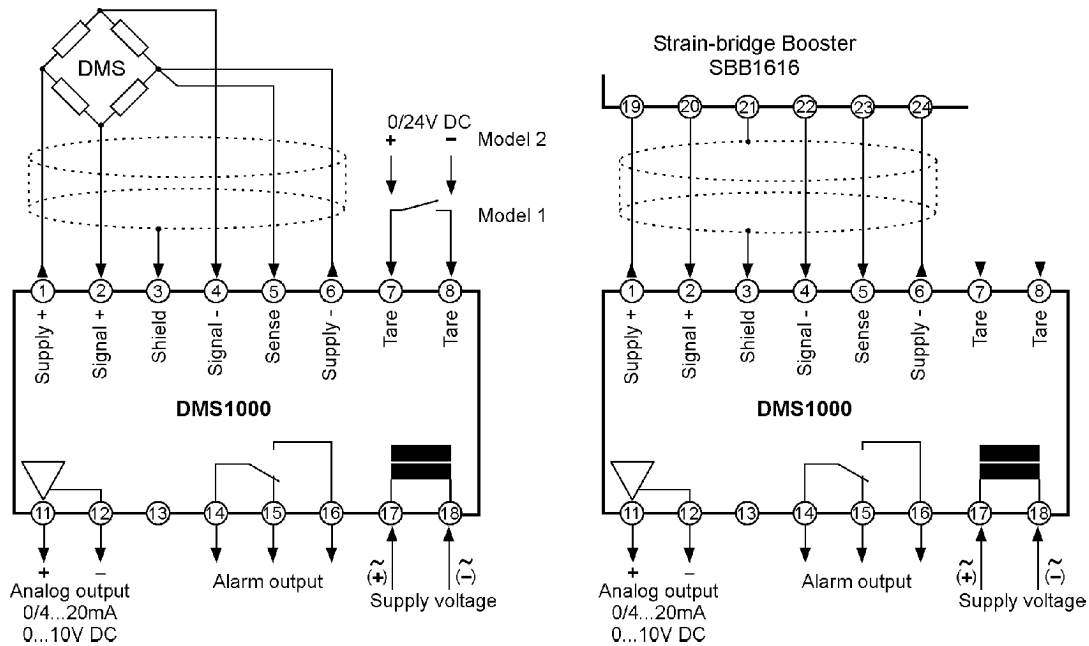

Controls and indicators

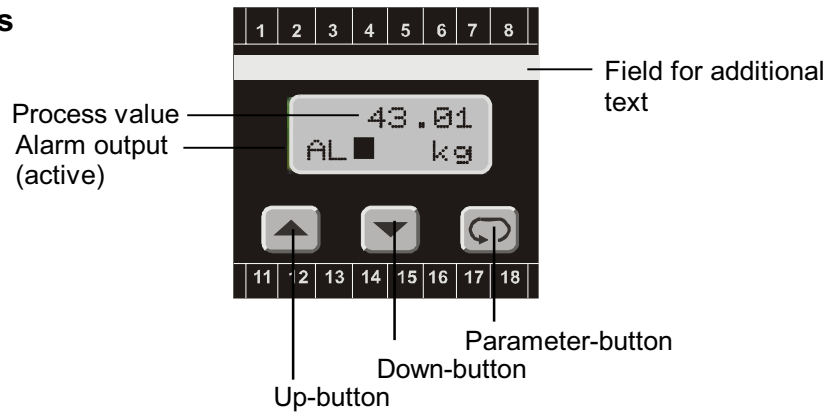

Description

Operation of the device is arranged in 2 levels. While programming, pressing button saves the current parameter and moves to the next programming step. Selection within a parameter or entering data, use buttons and .

Button combinations:

- + one parameter back.
- + setting parameter to zero or minimum value.

After powering up, the device initializes itself. The display shows the message DMS100 and Software Version **Version 1.1**. After the initializing procedure the device is running in the **Working level**. Set points of the alarm output can be selected and min- and max. values can be called up.

Activating the button for more than 2 seconds, the program is jumping into the **Configuration level**. The configuration level provides access to program all device functions. These are measuring input, input configuration, switching performance of alarm output and the analog output signal.

After finishing the configuration or when no button is pressed for more than 2 minutes, the program jumps back to the working level. Leaving the configuration level is possible at any time when pushing the button for 2 seconds.

Error messages:

Display flashes If the input signal leaves the programmed range, the display flashes.
P-E-R-R-O-R Factory calibration is necessary

Installation note!

Before the device can be used, it must be configured for the intended use.

⇒ see page 5



















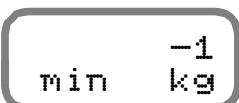

Notes to representation

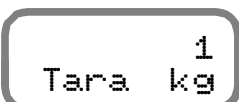
 Parameter only displayed if configured











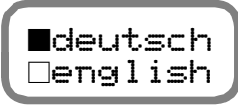





















Note:

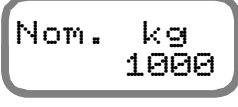



















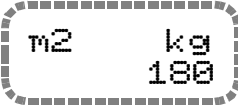

















All parameters can be called if they are not blocked by other programmed parameters

Working level

| Button | Display | Description |
|---|---|--|
|  |  | Process-value Indication of alarm output (only if activated). <input type="checkbox"/> = OFF and <input checked="" type="checkbox"/> = ON |
|  | | |
|  |  | Display peak reading Reset with buttons  or  , or at every power off. |
|  | | |
|  |  | Display valley reading Reset with buttons  or  , or at every power off. |
|  | | |
|  |  | Tare-function Pressing button  for more than 3 s , the display will be reset to "0". |
|  | | |
|  |  | Setpoint alarm output Setting possible in the programmed measuring range with buttons  and  . |
|  | | |

Configuration level

| Button | Display | Description | [displayed values are factory settings] |
|---|---|--|---|
|  press 2s ↓ |  | Language of the operating instructions Selection with buttons  and  . | |
|  ↓ |  | Digital filter. Averaging of the last measured values continuously. Selection with buttons  and  . | |
|  ↓ |  | Display unit kg, t, N, kN, bar Selection with buttons  and  . | |
|  ↓ |  | Fixed zero 0, e.g. 3690+0. Selection with buttons  and  . | |
|  ↓ |  | Decimal point position 0000; 000.0; 00.00; 0.000 Selection with buttons  and  . | |
|  ↓ |  | Measuring unit of the strain bridge (load cell) kg, t, N, kN, bar Selection with button  and  . | |
|  ↓ |  | Max. nominal load of the strain bridge (load cell) Setting possible from 1 ... 9999 Digit with buttons  and  . | |
|  ↓ |  | Bridge supply 2.5V, 5V, 10V DC Selection with buttons  and  . | |
|  | | | |

| Button | Display | Description | [displayed values are factory settings] |
|---|---|---|---|
|  |  | Teach-in function. Adjustment of the strain-bridge with reference weights to determine the bridge-sensitivity [mV/V]. Selection with buttons  and  . | |
|  | | | |
|  |  | 1. calibration point Setting possible in range of the programmed nominal load with buttons  and  . | |
|  | | | |
|  |  | 2. calibration point The difference to the 1.calibration point must be at least min 10% of the programmed nominal load. Setting possible with buttons  and  . | |
|  | | | |
|  |  | Bridge-sensitivity [mV/V] Setting possible from 0.100 ... 5.000mV/V with buttons  and  . | |
|  | | Note: When the teach-in function is accomplished, the calculated value of the sensitivity will be displayed. If this value is out of range an error message occurs and the value will not be stored. | |
|  |  | Direction of action. 1 - dir 0 ... measuring range; 2 - dir 0 ... ± measuring range. Selection with buttons  and  . | |
|  | | | |
|  |  | Analog output 0 - 20, 4 - 20 mA or 0-10V Selection with buttons  and  . | |
|  | | | |
|  |  | Start value for display range and analog output Setting possible from 0 (-9999) ... 9999 digit with buttons  and  . | |
|  | | | |
|  |  | End value for display range and analog output Setting possible from -9999 ... 9999 digit with buttons  and  . | |
|  | | Note: If MR Start > MR End, the output works with a decreasing characteristic. | |

| Button | Display | Description | [displayed values are factory settings] |
|--------|---------------------|---|---|
| ↓ ↺ | Alarm ▼ OFF | Switching performance alarm output OFF, MIN, MAX Selection with buttons ▲ and ▼ . | |
| ↓ ↺ | Setpoint 0 | Setpoint alarm output Setting possible within the programmed measuring range with buttons ▲ and ▼ . | |
| ↓ ↺ | Hyst. 1 | Hysteresis alarm output Setting possible within the programmed measuring range with buttons ▲ and ▼ . | |
| ↓ ↺ | Simul. 1850kg | Simulation of the load-cell The DMS1000 works as an simulator. The analog output changes within the programmed measuring range. Setting possible with the buttons ▲ and ▼ Please note: This parameter will not be left automatically after 120 seconds. | |
| ↓ ↺ | Corr.AO 0.000mA | Correction start value analog output Setting possible ±10% with buttons ▲ and ▼ | |
| ↓ ↺ | Corr.AO 20.000mA | Correction end value analog output Setting possible ±10% with buttons ▲ and ▼ | |
| ↓ ↺ | P-Lock ▼ OFF | Program lockout OFF = no lockout CONF IG = configuration level locked ALL = all parameters locked Selection with buttons ▲ and ▼ . | |
| ↓ ↺ | FactCode 0 | Code for factory settings | |
| | 450 AL■ kg | Back to the working level | |

Order code

DMS1000 - 1. - 2. - 3. - 4. - 5. - 6.

1. Model

- 1 Input Strain-Bridge(DMS-load cell),
integrated bridge-supply 2.5 / 5 / 10V DC max. 50mA,
input for extern tare function with voltage free contact
- 2 as before, but extern tare function with 24V DC tara signal
intern isolated by opto-coupler

2. Alarm output

- 1R 1 Alarm output relay SPDT

3. Analog output

- AO Analog output 0/4 ... 20mA ; 0... 10V DC,
not isolated to the measuring input

4. Supply voltage

- 0 230V AC ±10%
- 1 115V AC ±10%
- 4 24V AC ±10%
- 5 24V DC ±15%

5. Option

- 05 without Option

6. Additional text (appears on the face plate in the field additional text, maximum 3mm x 50mm wxH)

Ihr kompetenter Ansprechpartner / Your competent contact partner : * seit 1958 *

SCHRIEVER & SCHULZ & Co. GmbH Ing.- und Verkaufsbüro * Eichstr. 25 B, D - 30880 Laatzen
Tel ++49 (0) 511 86 45 41 / Fax ++49 (0) 511 86 41 56 * www.schriever-schulz.de | info@schriever-schulz.de